



# ALCN-792M and ALCN-792D

## Quad Loop Adder Motherboard and Daughter Board Installation Instructions

### ALCN-792M Quad Loop Adder Module with ALCN-792D Daughter Board

The ALCN-792M Quad Loop Adder module provides two addressable loops plus an additional two loops as part of the daughter board ALCN-792D which is mounted over the ALCN-792M. The Quad Loop Adder module may be mounted over the main chassis of the Network Fire Alarm Panel or on any chassis that supports adder boards. This module is mounted using four #6 screws and (if necessary) four 1 1/2" spacers.

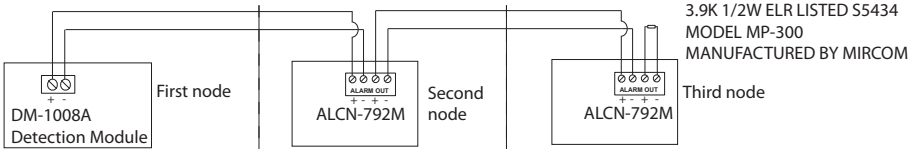
<b>Power</b>	The power is supplied to the board via cable from the main chassis board or from the previous loop controller module into the P1 POWER IN connector. Connect the P2 POWER OUT connector to the next loop controller module or other adder module. One power cable is supplied with this module.
<b>RS-485:</b>	The RS-485 cable comes attached at P3 and is either connected to P3 of the main fire alarm controller module or connected from the previous loop controller module or other adder board. If the next loop controller module is used, connect the RS-485 out at P4 to the next loop controller module; if it is not used, leave without connection.
<b>DIP Switches:</b>	Use the DIP switches to set the binary address of the board. SW1-1 is the lowest significant digit and ON is active. For example, an address of two would be created by turning SW1-1 OFF, SW1-2 ON and DIP switches SW1-3 to SW1-8 OFF. Refer to DIP switch settings in table below.
<b>Loop 1:</b>	This is the addressable loop for all initiating devices. Wire the loop as shown in the Network Fire Alarm Manual.
<b>Loop 2:</b>	This is the addressable loop for all initiating devices. Wire the loop as shown in the Network Fire Alarm Manual.
<b>Alarm:</b> (Optional redundancy wiring)	<p>Wire an initiating zone from the DM-1008A detection module to the alarm terminals of each ALCN-792M in series. The DM-1008A and each ALCN-792M must be on separate nodes. The last ALCN-792M must have a 3.9K resistor on the alarm terminal. This configuration provides standalone communication of alarms in the unlikely event of a communication failure between the ALCN-792M and the main board.</p> 
<b>Jumpers:</b>	A jumper is provided at JW2 for normal operation. To reset the board, leave the jumper at JW2 and momentarily short the pins at position JW1.
<b>RS-232 Debug Interface:</b>	This connection is for factory use only.
<b>JTAG Port:</b>	This connection is for factory use only.

### ALCN-792M DIP Switch Setting

Set the DIP switches on SW1 starting at address 1 for the first ALCN-792M adder and consecutively up to seven for the next six ALCN-792M modules. Refer to the Network Fire Alarm Manual for the maximum quad ALCN-792M adder modules allowed per node.

#### ALCN-792M Loop Adder Module Address Setting (DIP SWITCH SW1)

ALCN-792M	ADDR	SW1-1	SW1-2	SW1-3	SW1-4	SW1-5	SW1-6	SW1-7	SW1-8	
	1	ON	OFF	OFF	OFF	OFF	OFF	OFF	OFF	
	2	OFF	ON	OFF	OFF	OFF	OFF	OFF	OFF	
	3	ON	ON	OFF	OFF	OFF	OFF	OFF	OFF	
	4	OFF	OFF	ON	OFF	OFF	OFF	OFF	OFF	
	Refer to Network Fire Alarm Manual as to whether addresses 5, 6 and 7 are available									
	5	ON	OFF	ON	OFF	OFF	OFF	OFF	OFF	
	6	OFF	ON	ON	OFF	OFF	OFF	OFF	OFF	
7	ON	ON	ON	OFF	OFF	OFF	OFF	OFF		

Put in "ON" position for firmware restore to defaults during power up. At all other times put in "OFF" state.

## ALCN-792M Module Layout

The location of Loop 1 and 2 terminals on ALCN-792M Quad Loop Adder module are shown in Figure 1 below. Also shown are the power in and out cable locations and DIP switch location.

**Figure 1: ALCN-792M Quad Loop Adder Module**

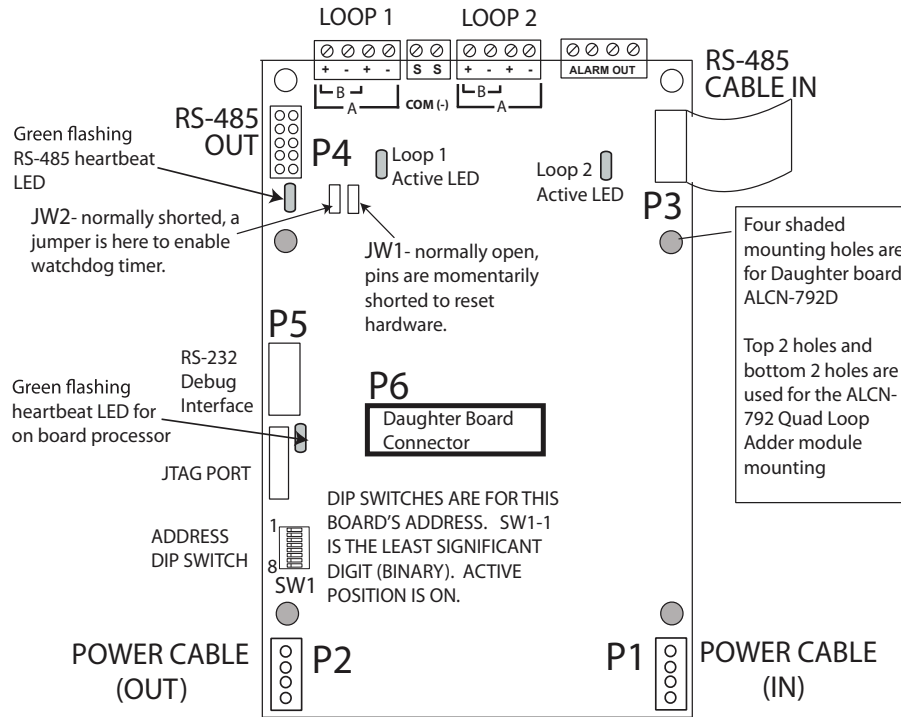

## ALCN-792D Daughter Board Mechanical Installation

The ALCN-792D Daughter Board provides another two addressable loops when connected to the ALCN-792M Quad Loop Adder Board. This daughter board is mounted over the ALCN-792M using the four screws and spacers provided. Wire the two addressable loops on the ALCN-792D Daughter Board in the same manner the ALCN-792M addressable loops are wired.

**Figure 2: ALCN-792D Daughter Board**

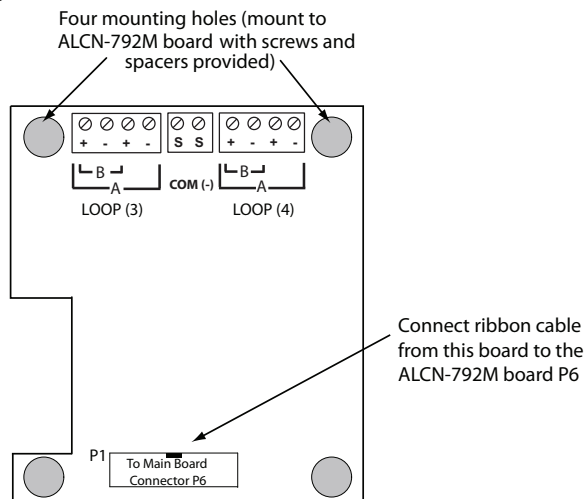

### Notes for ALCN-792M and ALCN-792D:

- All circuits are power limited and must use type FPL, FPLR, or FPLP power limited cable.
- Loop wiring: maximum loop resistance is 40 ohms total. These lines power-limited and fully supervised.
- For complete wiring instructions, refer to the Network Fire Alarm Manual